

**STEP 1** Determine if the wall has any deviations

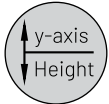

Before proceeding with construction, it is essential to confirm that the wall is structurally suitable, assess existing conditions, and determine any deviations in all three planes.

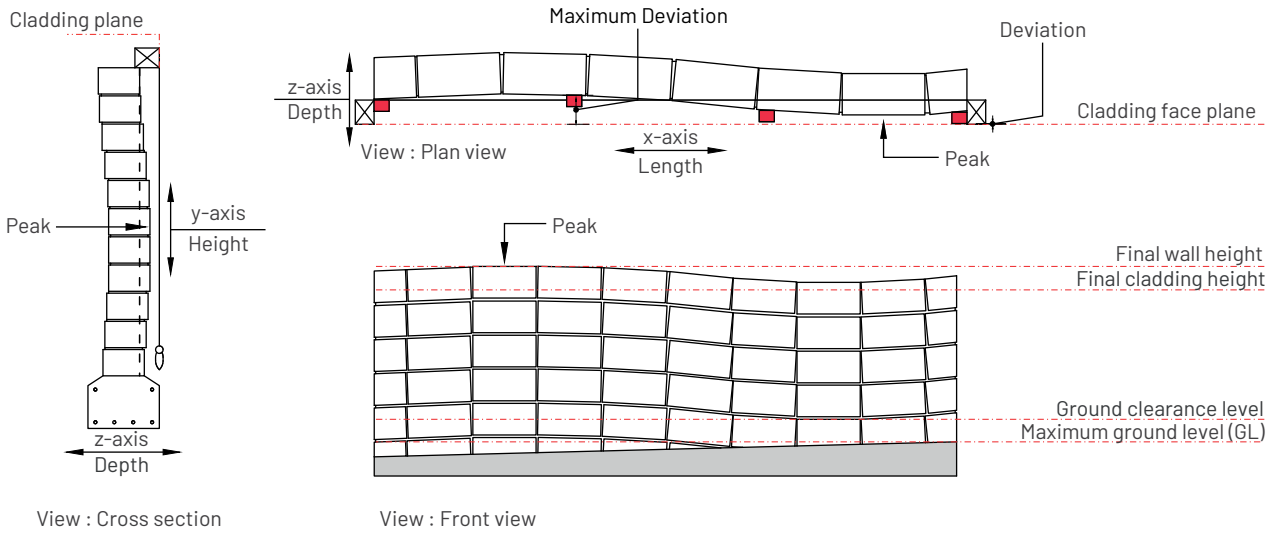
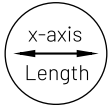

**STEP 2** Choose an appropriate clip strip for the application



The VistaClad system provides three clip strip options. The existing wall conditions may influence the choice in strip.

		$\pm 2 \text{ mm (0.08")}$ Allowable deviation				
<b>Flat clip strip</b>						
		$\pm 5 \text{ mm to } 8 \text{ mm (0.19") to (0.31")}$ Allowable deviation				
<b>Channel clip strip</b>						
		$\pm 5 \text{ mm to } 8 \text{ mm (0.19") to (0.31")}$ Allowable deviation				
<b>Top hat clip strip</b>						

**STEP 3** Choose a board and material technology

When selecting a material technology for the cladding system, it is crucial to consider how the material technology type, colour, and profile length will affect the final board length after installation. Board length is affected by temperatures on-site and will grow (expand) or shrink (contract) in relation to site temperatures. Trim can be used to conceal the change in length, resulting from these temperature changes. It is important to provide enough space to accommodate board expansion and ensure that the board will not contract past the trim. If expansion gap sizes are a concern, choose lighter coloured profiles and materials technologies with lower expansion coefficients. Alternatively consider shortening board length and using more butt joints within your planned board layout (See step 5). If the backside of the boards is exposed to UV rays, use a backing board or film. For guidance on how to calculate and account for expansion and contraction, consult the full installation guide.

**STEP 4 Determine the number of boards**

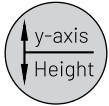

To establish the number of boards required for the cladding system, remove any additional clearances and trim edges from the full height of the wall before dividing this by the board coverage. Two typical board sizes are available 3" (requiring 76.3 mm Coverage) and 6" (requiring 152.6 mm coverage).

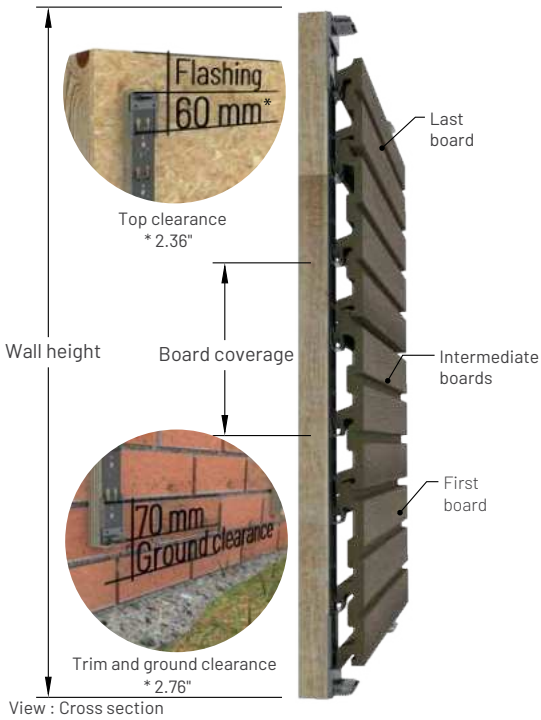

**1** Calculate the board quantity (BQ) =  $\frac{\text{Wall height} - \text{Flashing and trim gap} - \text{Ground clearance}}{\text{Board coverage (Typically 76.3 or 152.6)(3" or 6")}}$

Example  
 $BQ = (3000 \text{ Height} - 60 - 70 - 50) / 152.6$   
 $BQ = 2820 / 152.6$   
 $BQ = 18.47$  Boards over the height.

Imperial Example:  
 $BQ = (118.11 \text{ Height} - 2.36 - 2.76 - 2) / 6$   
 $BQ = 111.02 / 6$   
 $BQ = 18.47$  Boards over height

**2** Where the quantity of boards is not a whole number, a offcut will be required.  $\text{Offcut} = (BQ - \text{Whole boards}) * \text{Board coverage}$ .

Example  
 $\text{Offcut} = (18.47 - 18) * 152.6$   
 $\text{Offcut} = 0.47 * 152.6$   
 $\text{Offcut} = 71.72 \text{ mm}$ .

Imperial Example  
 $\text{Offcut} = (18.47 - 18) * 6$   
 $\text{Offcut} = 0.47 * 152.6$   
 $\text{Offcut} = 2.82 \text{ "}$

**3 Adjusting ripping size**  
 If the offcut is greater than the minimum requirement of 70 mm (2.76"), the last board can be ripped. Anything less than half of a full board will require additional adjustment as illustrated below.

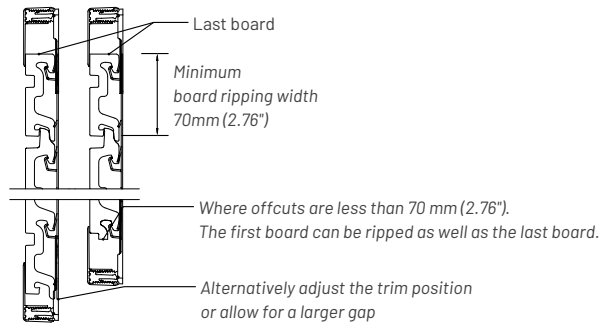

**STEP 5 Planning board layout**

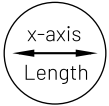

Once the wall has been assessed, the appropriate clip chosen and the number of boards calculated along the height of the wall, the horizontal laying pattern can be addressed.

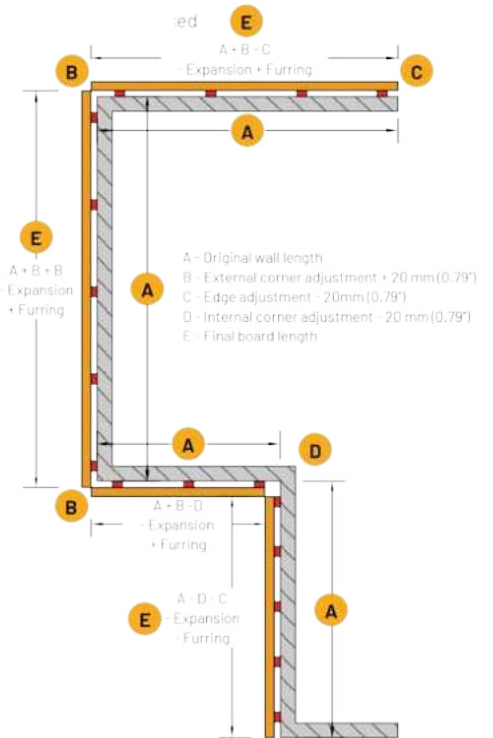
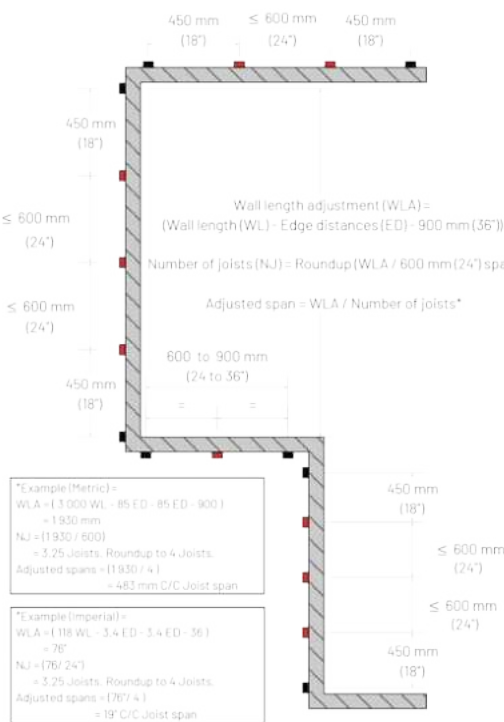
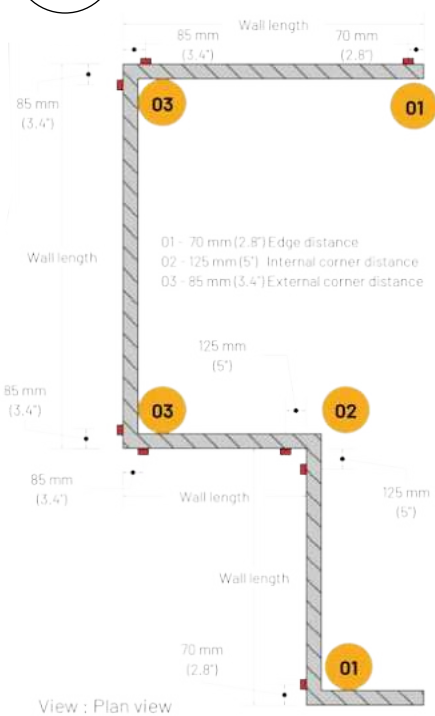

Identify the crucial dimensions of wall and plan the edge distances.

Plan the clip strip locations at appropriate spans. Typical spans are 600 mm (24") and typical edge spans are 450 mm (18").

Plan the final lengths for boards. Boards may extend past the wall or require additional space.

STEP 2a Horizontal installation

**1** Install furring. Ensuring that the furring is plumb, level in all three planes and at the spans needed to support the clip strips.

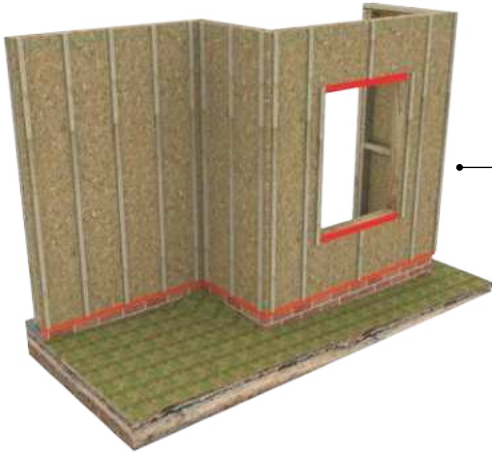

**2** Run a builders line between the two outermost points, 75 mm (3") (Remember to account for any additional space for flashing) from the top line of the cladding installation

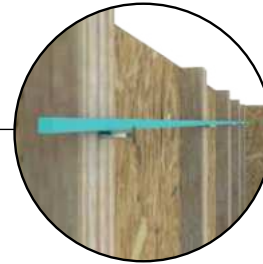

**3** Fasten small screws with heads smaller than 8mm (0.32") along the builders line at every furring strip.

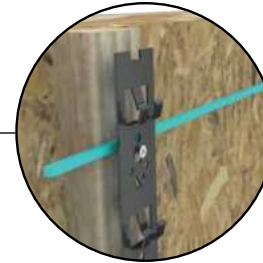

**4** Hang each clip after cutting the clip strip to length from the screw from the largest top most hole. As indicated in the image.

**Note:** Treat any exposed or cut steel edges before installation.

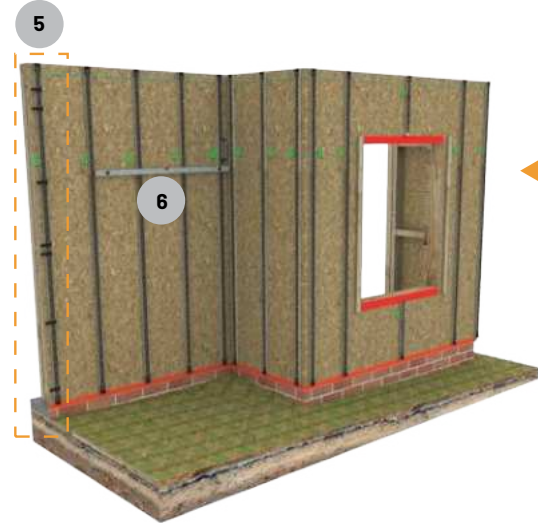

**5** "Lock" the first clip strip into place by fastening the strip in at least three locations at the required spans. This clip strip will become the reference point for all other clips strips.

**Note:** Once all clip strips have been fastened into place and are level, return to fasten the clips at the appropriate spans required for installation.



**Tip:** Use a torpedo level to check that the clip strip is plumb. The furring or intermediate structural parts should provide a level surface for the clip strip.

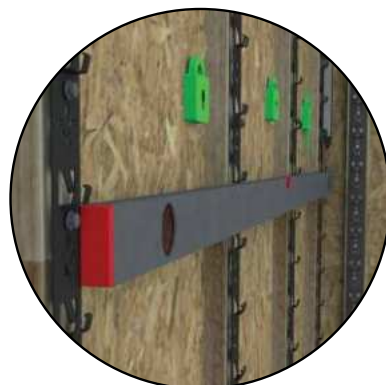
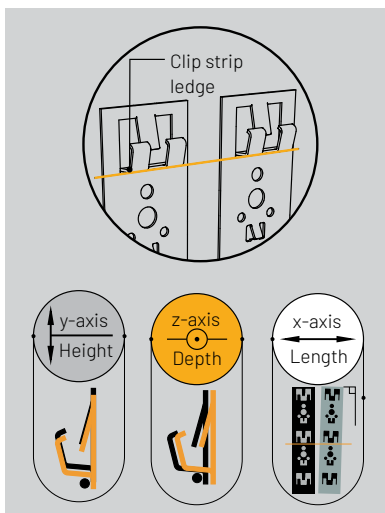

**6** Level the clip strips (as illustrated) in all 3 planes. The clip strips ledge provides the most convenient and accurate point of reference.

**Tip:** Use a straight edge and level at least three times the span, to level the clip strips.

**Note:** Once all clip strips have been fastened into place and are level, return to fasten the clips at the appropriate spans required for the installation.

**STEP 2b Vertical installation**

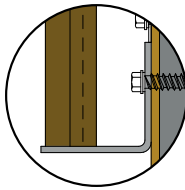
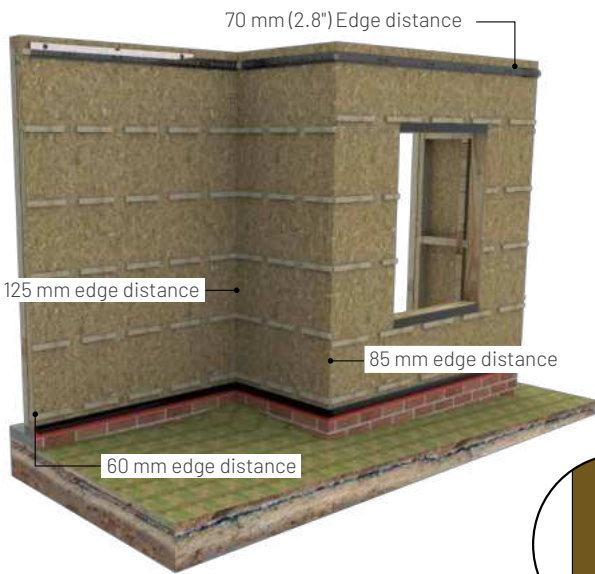

**1** Install furring. Ensuring that the furring is plumb, level in all three planes and at the spans needed to support the clip strips. Provide gaps for ventilation and drainage.

**Note:** Do not use flat strips for vertical applications. Top hat clip strips are best suited to the application and require no additional furring.

**2** Vertically laid boards require additional support as they will slide down.

Install a structural element with drainage holes (Perforated angle). Allow for 1500 to 2500 mm<sup>2</sup>/m (0.71 to 1.18 in<sup>2</sup>/ft) perforations with holes no larger than 9.5 mm (0.37").

Structural elements can be 2.0\* mm (0.08") thick for steel and 2.5\*mm (0.1") thick for aluminium. Width and height would depend on the clip and board combination.

\*Thickness is based on the assumptions that the structural element will be supporting a board load of 16 kg/m<sup>2</sup> (3.28lb/ft<sup>2</sup>). (board length is a maximum of 5.8m (19'))

**3** Fasten each horizontal strip at the top two most extreme edges ensuring that they are level.

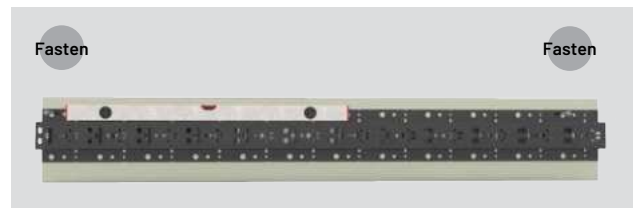
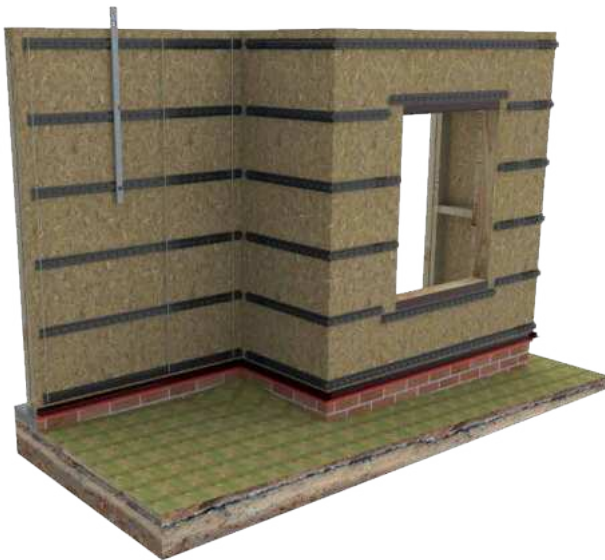

**4** As per step 6 of the horizontal installation, use levels or plumb lines to ensure that the ledges are aligned.

**5** Install additional perforated angles where vertical boards may require support, such as window lintels and butt joints.

**Note:** Once all clip strips have been fastened into place and are level, return to fasten the clips at the appropriate spans required for the installation

**STEP 2c Channel and top hat clip strips**

Both channel clip strips and top hat clip strips are rigid members that are capable of spanning. Additional fastening points have been provided along the side faces of the channels and top hats to allow for wall deviations as indicated on page 1. The size of these members allow for fastening or clipping over 1.5" or 38 mm structural members and composite battens. When fastening from the side ensure that the edge distances within the structure are adequate.

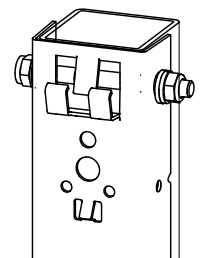
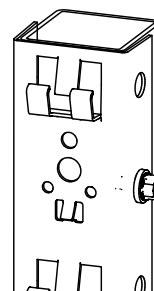
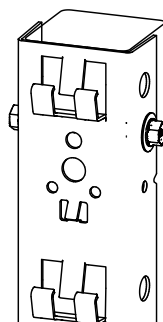
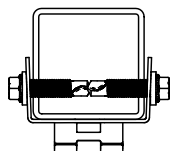
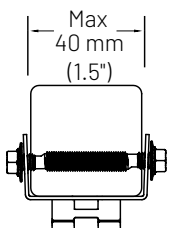

VistaClad has a trim adaptor and aluminium trim available for a quick and neat installation. Adaptors fastened to the clip strip remove the need for fastening through composite profiles. Trim adaptors must be installed before boards.

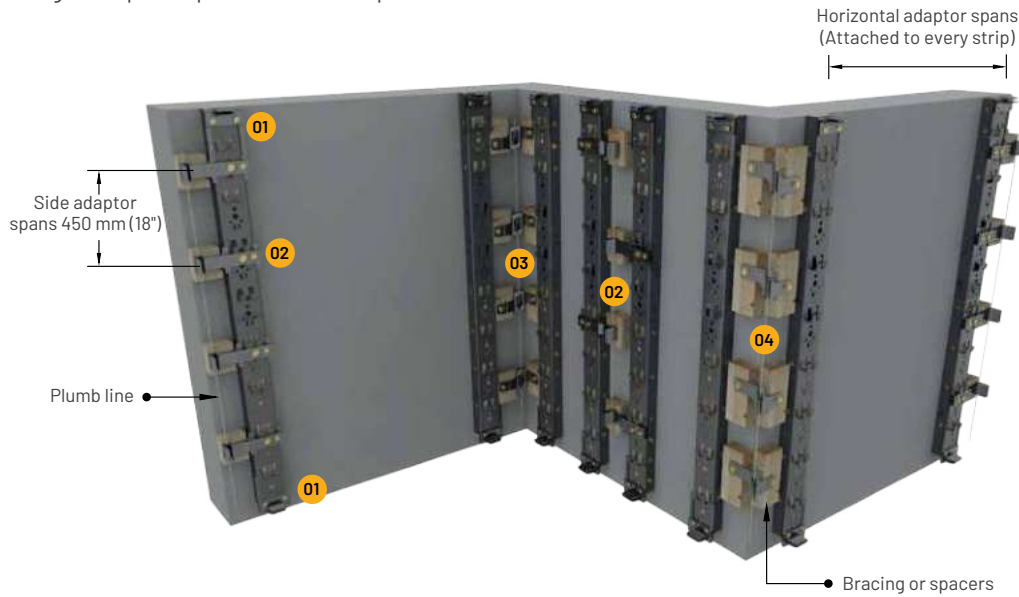

**Note:** Ensure that there is support behind the clip strip when fastening adaptors. VistaClad trim and adaptors are used to cover board edges and additional flashing may need to be installed at this phase. See the flashing section on page 12 before continuing.

- 01 - Top and bottom adaptor
- 02 - Side adaptor
- 03 - Internal corner adaptor
- 04 - External corner adaptor

### Side adaptor

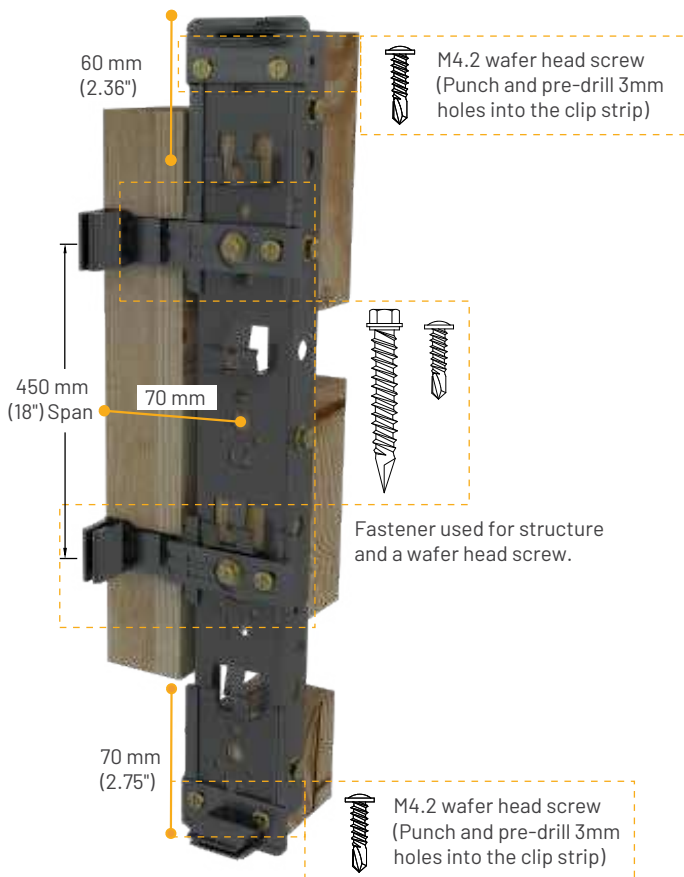

### Butt joins with side adaptor

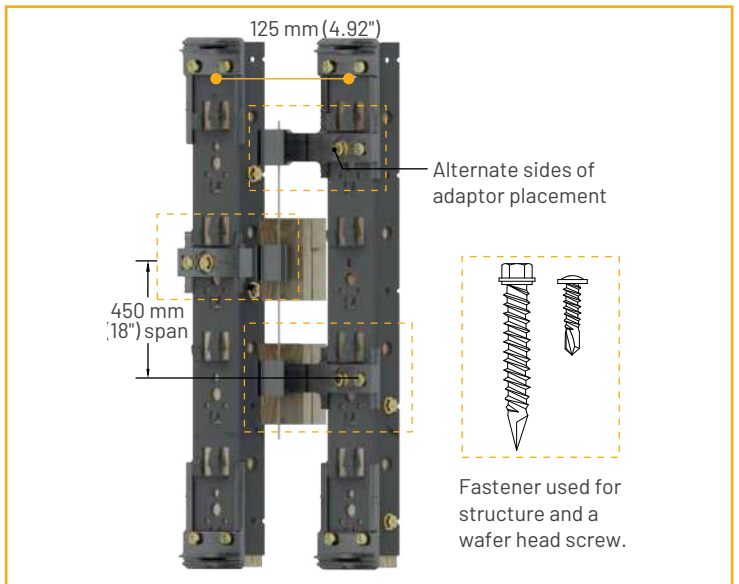

Double up on adaptors around trim joins.

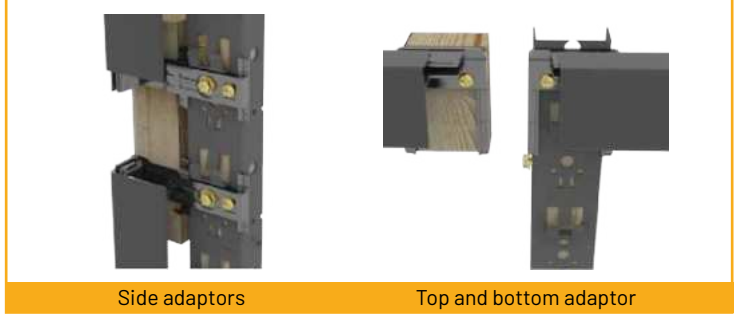

Side adaptors

Top and bottom adaptor

Internal corner adaptor

125 mm (4.92") 125 mm (4.92")

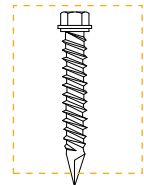
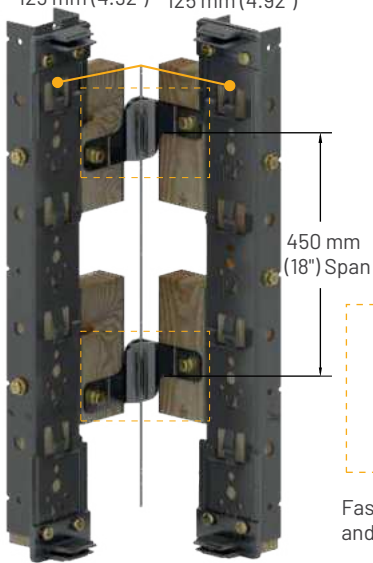

Fastener used for structure and a wafer head screw.

External corner adaptor

85 mm (3.35") 85 mm (3.35")

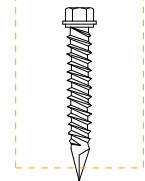
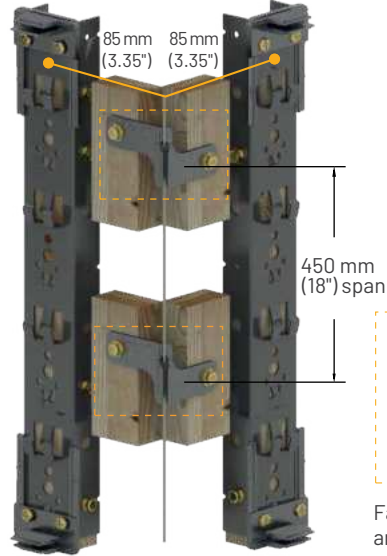

Fastener used for structure and a wafer head screw.

VistaClad trim adaptors in vertical installations

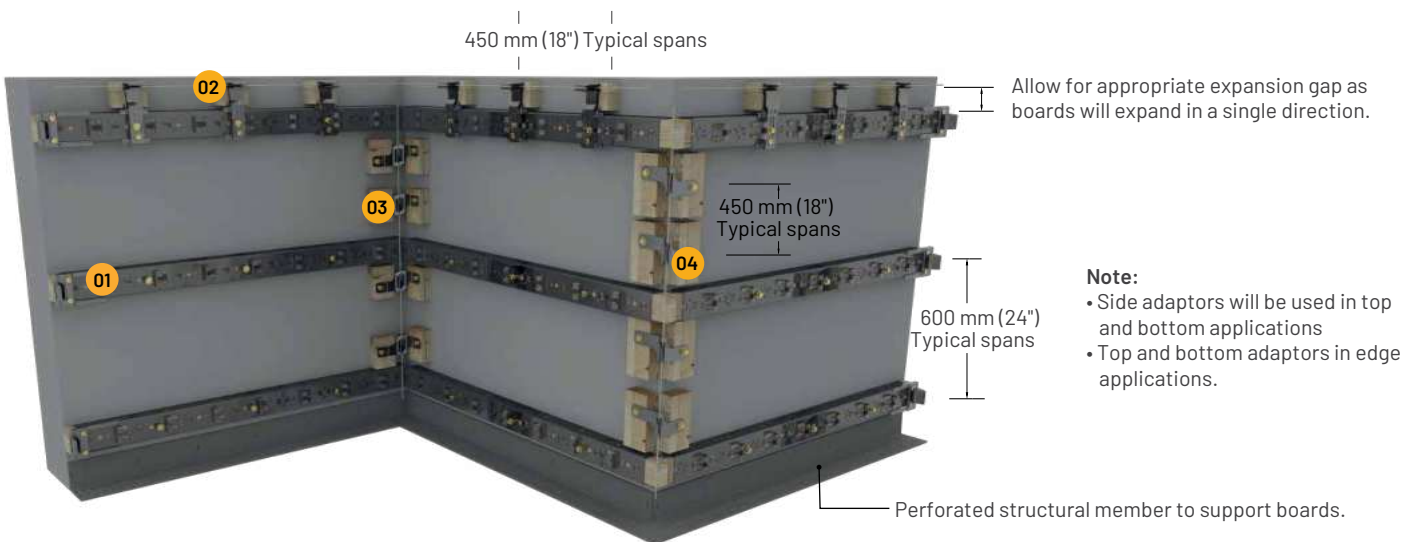

- Note:**
- Side adaptors will be used in top and bottom applications
  - Top and bottom adaptors in edge applications.

VistaClad clip strip fasteners

VistaClad clip strips provide several fastening opportunities for various types and sizes of screws.

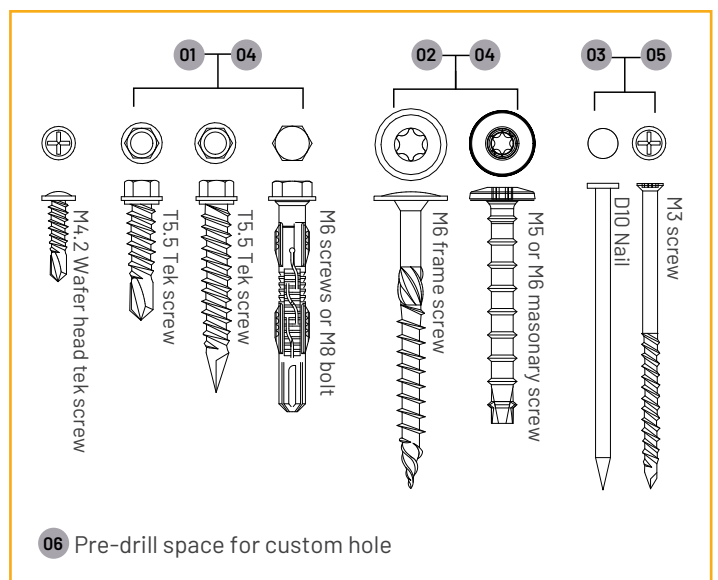
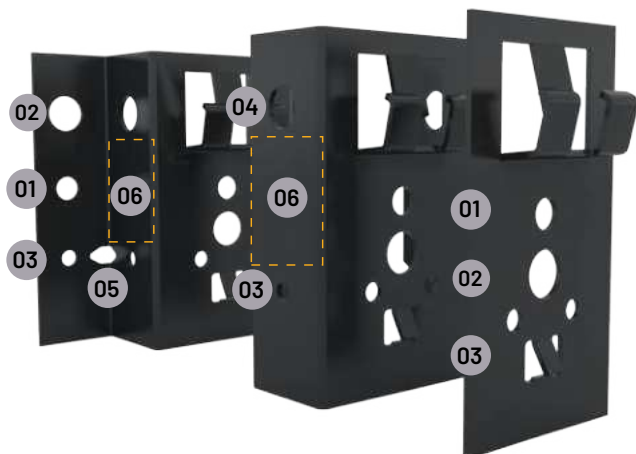

**STEP 4a** Horizontal installation

**Align the first board with the clip**

Fully supporting the full length of the board. Place the board above the clip. Aligning the feet with the clip hooks.



**Note:** At lengths of larger than 4 spans, two people should install the board

**Press down**

Start at one side of the board and push or lightly knock the top of the board with a soft mallet into the board's final position.

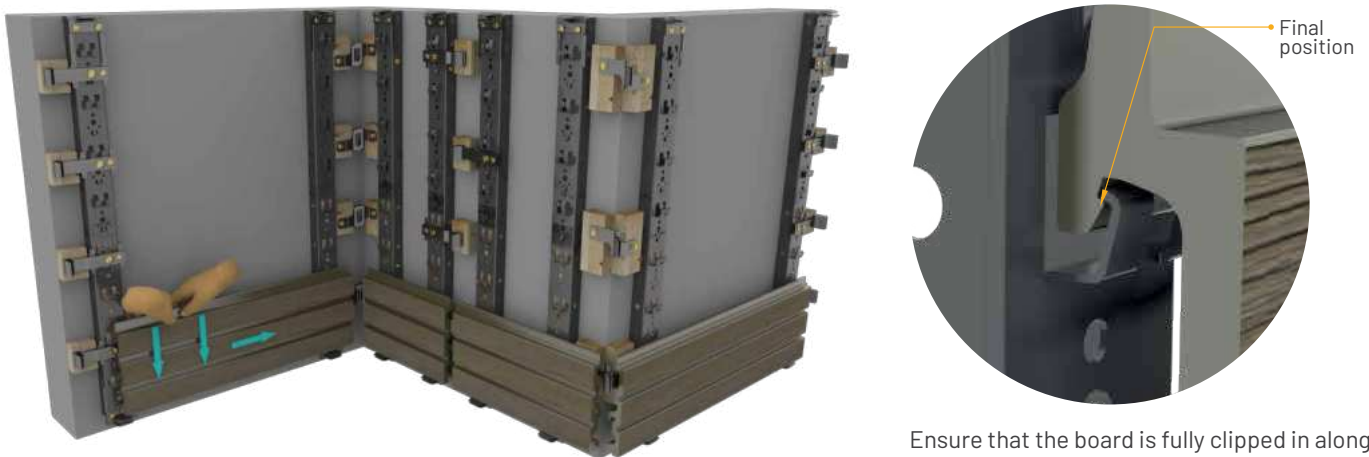

Ensure that the board is fully clipped in along its full length before starting the next board

**Align the next board and press down**

Align the board against the tongue of the previously installed board and placing the board against the clip. Press down from one side of the board to the other.

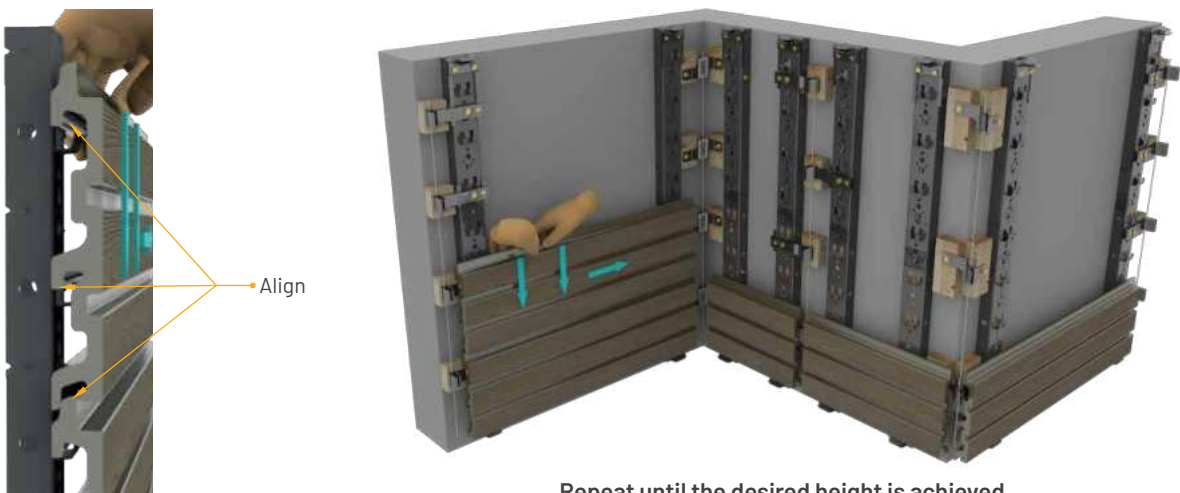

Repeat until the desired height is achieved

**STEP 4b** Vertical installation**Align the first board with the clip**

In vertical applications boards over 3 m (10") may be prone to buckling before insertion. A minimum of two installers are recommended. Ensure that the top of the board is fully supported before attempting to insert the board.

**Press down**

Start from the top of the board, push or lightly knock the top of the board with a soft mallet into the board's final position.

**Press down**

In vertical applications, provide enough clearance in internal corners to insert the next set of boards. This can be achieved by inserting boards from a single direction.





Click the pre-cut trim into the adaptor and adjust it to the correct position\*

\*Note: Adjust the trim to the correct position before fully engaging the adaptor

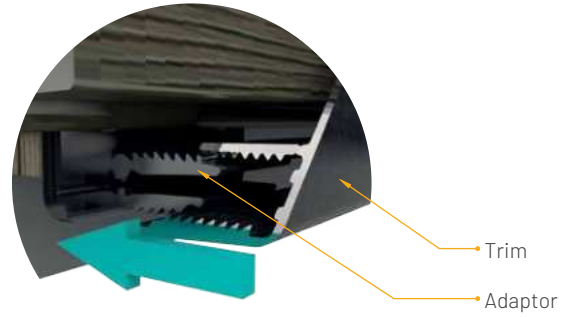

Click the trim in over the adaptor until they can go no further.

Apply a 5 mm (0.2") Ø bead of Caulking material along the trim. Before pushing the trim into the adaptors, directly over the

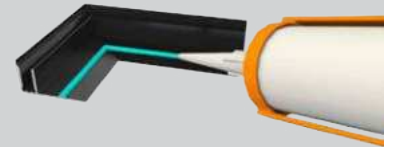

Joining VistaClad trim

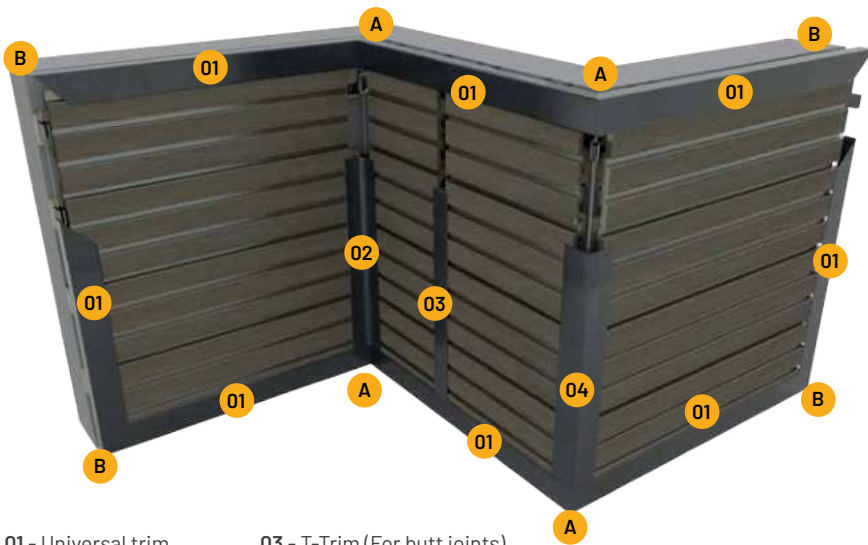

- 01 - Universal trim
- 02 - Internal corner trim
- 03 - T-Trim (For butt joints)
- 04 - External corner trim

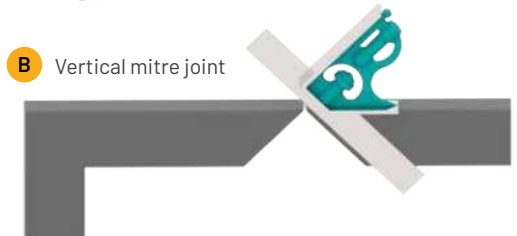
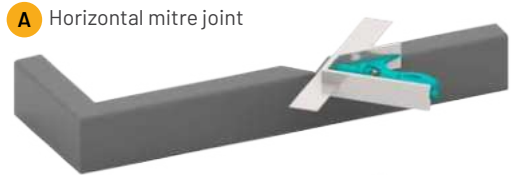

Apply caulking to full board grooves. Clear away excess.



Potential Caulking options

- Loctite 100% Silicone
- Loctite PL Roof and Flashing Sealant
- Alcolin Alco Flex Neutral Silicone

Finishing without VistaClad trim



Use Z flashing and angles for edges and heads



Butt joints will be exposed. Allow for expansion gaps.



Mitre cut Internal corners. Allow for expansion gaps.



Mitre cut external corners. Allow for expansion gaps.